

**NATIONAL UNIVERSITY OF SCIENCE AND TECHNOLOGY**

FACULTY OF INDUSTRIAL TECHNOLOGY  
BACHELOR OF ENGINEERING (HONS) DEGREE  
Part One Examination January 2008

**TCE1101 Chemical Engineering Calculations**

Duration of Examination 3 Hours

Instructions to Candidates:

1. Answer ALL FIVE questions.
2. Each question carries equal marks.
3. Show all your steps clearly in your calculation.
4. Start the answers for each question on a new page.

---

**1.**

**a)** Silver nitrate (lunar caustic) is a white crystalline salt, used in marking inks, medicine and chemical analysis. How many kilograms of silver nitrate ( $\text{AgNO}_3$ ) are there in :

- i) 13.0 lb mol  $\text{AgNO}_3$ .
- ii) 55.0 g mol  $\text{AgNO}_3$

(10 marks)

**b)** The density of a liquid is  $1500 \text{ kg/m}^3$  at  $20^\circ\text{C}$ .

- i) What is the specific gravity  $20^\circ\text{C}/4^\circ\text{C}$  of this material.
- ii) What volume ( $\text{ft}^3$ ) does 140 lbm of this material occupy at  $20^\circ\text{C}$ .

(10 marks)

**2.**

**a)** A solvent storage tank, 15.0 m high contains liquid styrene (sp. gr. 0.909). A pressure gauge is fixed at the base of the tank to be used to determine the level of styrene.

- a. Determine the gage pressure when the tank is full of styrene.
- b. If the tank is to be used for storage of liquid hexane (sp. gr. 0.659)
- c. What will be the new pressure with hexane to indicate that the tank is full.

(7 marks)

**b)** A liquid adhesive, which is used to make laminated boards, consists of a polymer dissolved in a solvent. The amount of polymer in the solution has to be carefully controlled for this application. When the supplier of the adhesive receives an order for 3000 kg of an adhesive solution containing 13 wt % polymer, all it has on hand is (1) 500 kg of a 10 wt % solution, (2) a very large quantity of a 20 wt % solution, and (3) pure solvent.

Calculate the weight of each of the three stocks that must be blended together to fill the order. Use all of the 10 wt % solution.

(13 marks)

**3.**

**a)** The synthesis of ammonia proceeds according to the following reaction

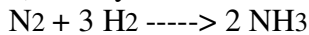

In a given plant, 4202 lb of nitrogen and 1046 lb of hydrogen are fed to the synthesis reactor per hour. Production of pure ammonia from this reactor is 3060 lb per hour.

- What is the limiting reactant.
- What is the percent excess reactant.
- What is the percent conversion obtained (based on the limiting reactant).

(12 marks)

**b)** Methane is burned to form  $\text{CO}_2$  and  $\text{H}_2\text{O}$  in a batch reactor:

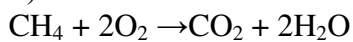

The feed to the reactor and the products are shown:



- How much methane was consumed and what was the fractional conversion of methane?
- How much oxygen was consumed and what was the fractional conversion of oxygen?

(8 marks)

**4.**

**a)** Many chemicals generate emissions of volatile compounds that need to be controlled. In the process shown in the accompanying figure, the CO in the exhaust is substantially reduced by separating it from the reactor effluent and recycling the unreacted CO together with the reactant. Although the product is proprietary, information is provided that the fresh feed stream contains 40% reactant, 50 % inert and 10 % CO, and that on reaction 2 moles of reactant yield 2.5 moles of product. Conversion of the reactant to product is 73 % on one pass through the reactor, and 90 % for the over all process. The recycle stream contains 80% CO and 20% reactant. Calculate the ratio of moles of the recycle stream to moles of the product stream.

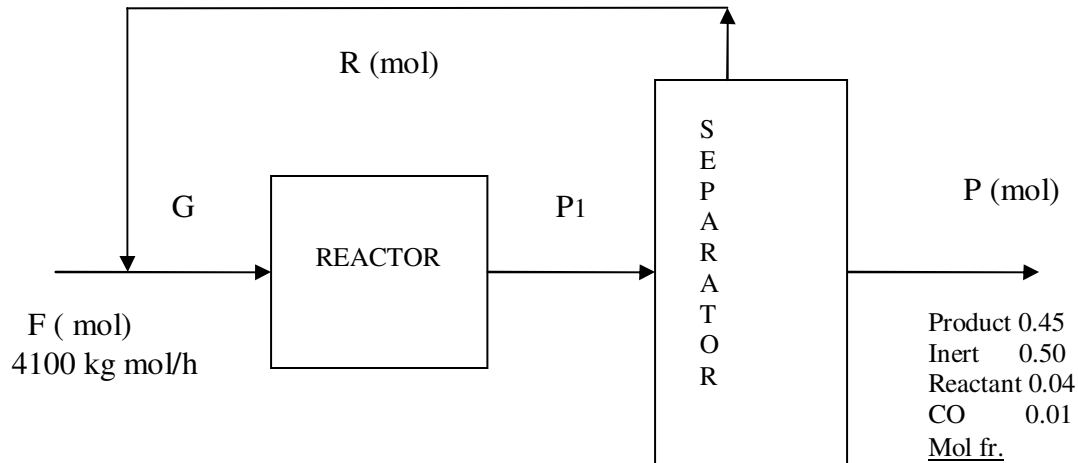

(14 marks)

**b)** A steel container has a volume of 200 m<sup>3</sup>. It is filled with nitrogen at 22°C and atmospheric pressure. If the container valve is opened and the container heated to 200°C, calculate the fraction of the nitrogen which leaves the container.

(6 marks)

**5.**

**a)** An old way of producing hydrogen gas in the laboratory was by the reaction of sulfuric acid with zinc metal

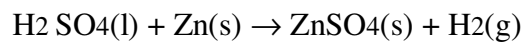

How many grams of sulfuric acid solution (98%) must act on an excess of zinc to produce 12.0 m<sup>3</sup>/hr of hydrogen at standard conditions. Assume all the acid used completely reacts.

(8 marks)

**b)** A shock tunnel uses hydrogen as its driving gas. The hydrogen at high pressure is restrained by a metallic membrane. When the membrane is ruptured, the hydrogen bursts into the evacuated section and a researcher can study high intensity shock waves. Given the data on the schematic diagram of the tunnel, determine the final temperature and pressure of the gas. The process occurs quickly, before any appreciable heat transfer can occur between the gas and the walls of the chamber. (12 marks)

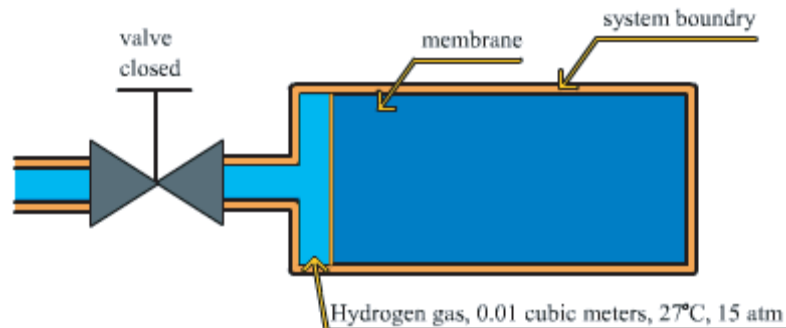

Basis: 0.01 m<sup>3</sup> of H<sub>2</sub> at 27°C, 15 atm.

