

NATIONAL UNIVERSITY OF SCIENCE AND TECHNOLOGY

FACULTY OF INDUSTRIAL TECHNOLOGY
BACHELOR OF ENGINEERING (HONS) DEGREE
Part Two Examination April 2009

TCE 2105 Fluid Flow

Duration of Examination 3 Hours

Instructions to Candidates:

1. Answer ALL FIVE questions.
2. Each question carries equal marks.
3. Show all steps clearly in your calculation.
4. Start the answers for each question on a new page.

1. a) An inclined tube manometer consists of a vertical cylinder 35mm diameter. At the bottom of this is connected a tube 5mm in diameter inclined upward at an angle of 15 to the horizontal, the top of this tube is connected to an air duct. The vertical cylinder is open to the air and the manometric fluid has relative density 0.785. Determine the pressure in the air duct if the manometric fluid moved 50mm along the inclined tube.

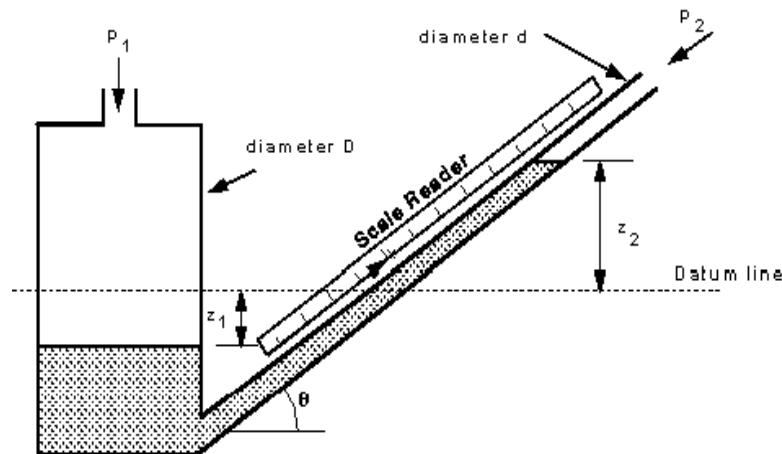

(6 marks)

b) Define the following terms in connection with the flow of a liquid (a minimum of three lines per description is required – preferably more with simple examples):

- | | |
|---------------------------|-----------------------------|
| i. Uniform flow | v. Discharge |
| ii. Steady flow | vi. Mass flow rate |
| iii. Unsteady flow | vii. Continuity |
| iv. Mean velocity | viii. Boundary layer |

(14marks)

2. a) A Venturi meter is being calibrated in a laboratory. The meter is lying horizontally and has a diameter of 75 mm at the entrance and 50 mm at the throat. The flow rate is obtained by measuring the time required to collect a certain quantity of water. The average number of such measurements gives 0.614 m³ of water flowing in 55.82 seconds. If the pressure gauge at the throat reads 20 kN/m² less than that at the entrance, calculate the head loss due to friction using the Bernoulli equation. **(12marks)**
- b) What is meant by the Net Positive Suction Head (NPSH) required by the pump? Explain why it exists and how it can be made as low as possible. What happens if the necessary NPSH is not provided? **(8 marks)**
3. a) Using the Bernoulli equation, show that the discharge through an orifice is given by $Q = C_d A_o \sqrt{2gh}$, where A_o is the area of the orifice and h is the head of water above the orifice. **(5 marks)**
- b) A tank of water is 5.6 m by 4.3 m in plan with vertical sides. Water from the tank discharges to the atmosphere through a 200 mm diameter orifice in the base. Over a period of 5 mins 7 secs the water level drops from 1.9 m to 0.7 m above the orifice. What is the value of the coefficient of discharge of the orifice? Work from first principles. **(15 marks)**
4. A pipeline of constant 0.6 m diameter with its centre line in the horizontal plane turns through an angle of 75°. The pipeline carries water at the rate of 0.85 m³/s. A pressure gauge at the bend indicates that the pressure is equivalent to 41.3 m of water. Calculate the force exerted on the bend by the water and the direction it acts. **(20 marks)**
5. a) 75% sulphuric acid, of density 1650 kg/m³ and viscosity 8.6 mN s/m², is to be pumped for 0.8 km along a 50mm internal diameter pipe at the rate of 3.0 kg/s, and then raised vertically 15m by the pump. If the pump is electrically driven and has an efficiency of 50%, what is the power required? What type of pump would you use and of what material would you construct the pump and pipe? Take $R/\rho u^2 = 0.004$ ($e = 0.046\text{mm}$) **(14 marks)**
- b) Describe how an Air Lift pump works. **(3 marks)**
- c) The advantages and disadvantages of reciprocating pumps in general over centrifugal pumps. **(3 marks)**