

NATIONAL UNIVERSITY OF SCIENCE AND TECHNOLOGY

FACULTY OF INDUSTRIAL TECHNOLOGY

BACHELOR OF ENGINEERING (HONS) DEGREE

Final Examination May 2011

TEE 1202 GRAPHICS AND DESIGN FOR ELECTRONIC ENGINEERS

Duration of Examination 3 Hours

Instructions to candidates:

1. Answer **ALL** questions from section A.
2. Answer one question from section B.
3. All questions carry equal marks (25)
4. Create a new folder and name it "user name **TEE1202 EXAM**" in your profile . eg "skomichi**TEE 1202EXAM**"
5. Save all your answers in your profile inside Folder "user name **TEE 1202 EXAM**"
6. Make sure your **ANSWERS ARE SAVED** in the right place
7. Save Question 1 as Q1, Question 2 as Q2 , etc

SECTION A

Answer all questions

Question 1

A 3 bit machine has to count products for grading and packaging purposes into cases. Each package case should be a set of 210 similar size items. The machine count does not exceed a count of three bits at once. This means maximum machine count per given time is 7 or any number below 7.

- a) Using a flowchart design a program for the above counting machine.
- b) Using Cadkey show the flowchart and label the diagrams.

Question 2

Design an inverting operational amplifier with a gain of 10 using the following components.

- ↓ Input Supply of -170/170V 60Hz from Analog Signal Generator.
- ↓ UA741.
- ↓ 100K, 10K and 25K; for R_L , R_f and R_{in}
- ↓ V_{cc} and V_{EE} are $-/+12V$

- a) Show the Schematic circuit in your answer book.
- b) Using CircuitMaker design the amplifier and show your simulations.
 - i. Write down V_{out} and V_{in} .
 - ii. Calculate the gain.
 - iii. Show both input and output voltages on simulation
 - iv. Show the frequency of the input and output signals. [25]

Question 3

Design the printed circuit board for the following circuit. Using Traxmaker show the graphical representation of the PCB.

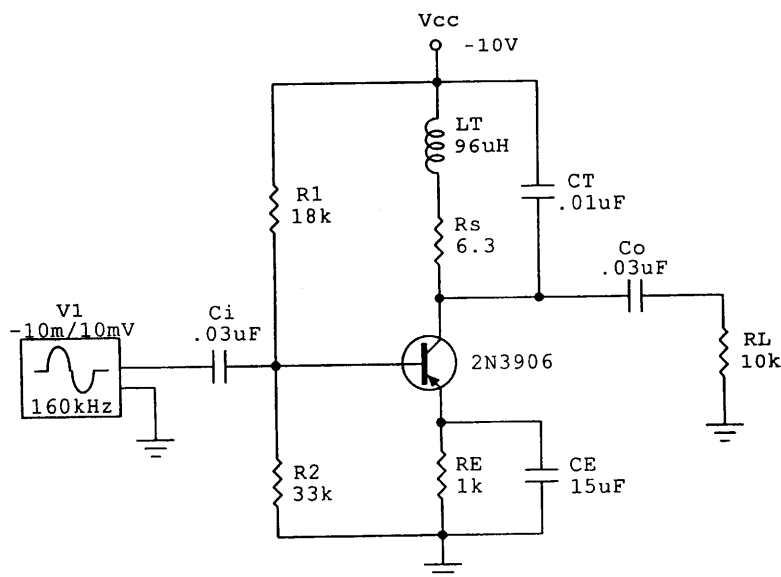

[25]

SECTION B

Answer one question.

Question 4

The motherboard of a personal computer carries a microprocessor (type NUST100) which has a data bus of 16 lines, and an address bus of 22 lines (numbered 0 to 21). The board incorporates two memory chips (M1 and M2), and an input/output chip (PIA). All the lines of the data bus are connected from NUST100 to each of the other three chips. The address bus from NUST100 is split so that lines 0 to 10 go to M1, while 0 to 9 plus 11 go to M2. lines 18 to 21 go to the PIA.

Draw a schematic block diagram for the motherboard using Cadkey. [25]

Question 5

An electrolysis method is used for extraction of gold from the ore in a gold processing plant. The electrolyte used is a cyanide solution. The cyanide concentration and consequently the pH of the solution is closely controlled for maximum extraction. A pH of 2.4 is to be maintained. Should the pH exceed 2.4 a signal is sent to the central processing unit and the cyanide tank valve is closed so that no more cyanide is added to the solution, and should the pH drop below 2.4 a signal is sent to the central processing unit and the cyanide tank valve opens so that more cyanide is added to the solution. This ensures that the pH remains constant. Should there be extreme deviation of pH a signal is generated so that the plant stops instantly. Using a flowchart, design a program to implement the above processing plant. Using any software program of your choice draw the flowchart.

Question 6

Design a logic circuit using AND, OR, NAND, NOR or NOT gates to implement the following equation.

$$M = (((W \text{ AND } X) \text{ OR } (Y \text{ AND } Z)) \text{ OR } ((/W \text{ AND } /Y) \text{ OR } (/X \text{ AND } /Z))) \text{ AND } (W \text{ OR } Z)$$

where W, X, Y, Z are inputs and M is output. A slash "/" means that a value is complimented (i.e. NOT operation is performed on it).

Present your design as a circuit diagram using CircuitMaker.

End of Exam